

LB2250

Line Boring Machine

Operational Benefits

- ✓ **Powerful**
Produces high torque at the bar using specially-designed rotational drive
- ✓ **Versatile**
Highly customizable to meet a variety of needs. Come with pneumatic motor – hydraulic motor is optional.
- ✓ **Quick and Easy Setup**
Modular components make setup quick and easy
- ✓ **Compact**
Extremely portable & compact for ease of use in tight & cramped workspaces
- ✓ **Flexible & High Quality Design**
Through-bar design allows the rotational drive and feed unit to be mounted anywhere along the bar

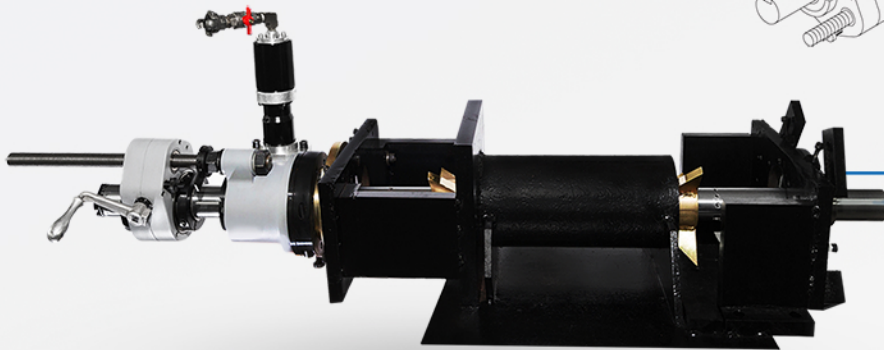

Features

Our LB2250 is a versatile line boring machine for the global market. One of its distinct advantages is its reliability in usage for tight spaces. You'll be amazed at the power and flexibility of the LB2250 Line Boring Machine. Mounting components provide the flexibility to handle tough boring jobs, even when used in cramped, tight workspaces.

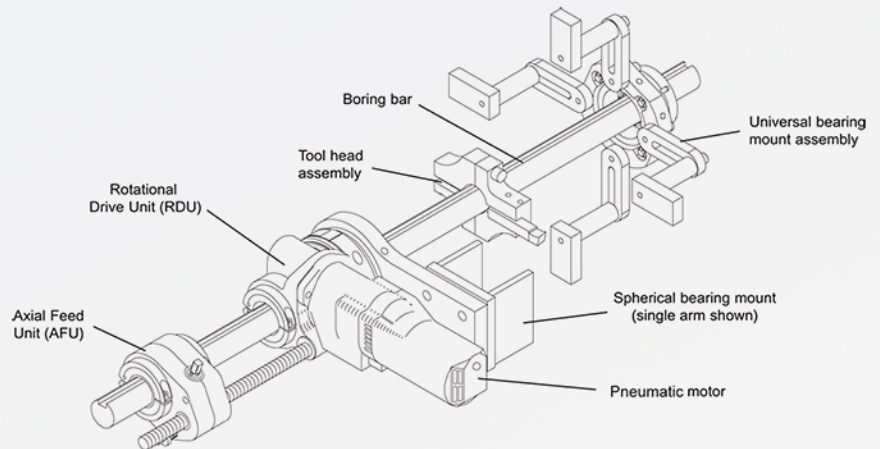

Technical Specifications

Designed for different industries



Model LB2250	Imperial / US	Metric
Boring diameter	2 1/8" to 24"	64 to 610 mm
Boring bar Ø standard	2 1/4"	57.15 mm
Boring stroke (maximum)	36"	915 mm
Torque at bar (hydraulic)	420 ft. lb	566 mm
Feed rate per revolution	0" to 0.019"/rev	0 to 0.48 mm/rev
Power (hydraulic motor)	9.4 hp	7.0kW
	Up to 245 free speed bar RPM	
Power (pneumatic motor)	1.45 hp	1.1kW
	Up to 220 free speed bar RPM	
Rotational drive ratio	4-in-1 Gear ration reduction	
Mounting type	Single arm, double arm or universal	
Set up cones	Ø2 3/4 to Ø7 1/2"	Ø70 mm to Ø190 mm
Weight (typical)	444 lb	202 kg

SCAN ME



Tel: +65 6271 0800
 Fax: +65 6273 3121
enquiries@petracarbon.com
www.petracarbon.com

