

# Flange and Internal Weld Testers for Hydrostatic Testing



[www.inpipeproducts.com](http://www.inpipeproducts.com)

# Progressive, Responsive and Knowledgeable

Supplier of pipeline maintenance and testing equipment

**iNPIPE PRODUCTS™** has been designing and manufacturing weld testing equipment for over 30 years and has the benefit of the largest hire fleet in Europe based at a central location in North Yorkshire. 24 hour service coverage is offered to all parts of England, Scotland, Ireland and Wales with tool only or tool and manpower options readily available.

**iNPIPE PRODUCTS™** flange weld testers provide accurate localised pressure testing of new flange welds. This is of particular benefit when pipeline modifications and old pipe work repairs are conducted as they purely test the new weld and not the whole system.

Pressure testing of an old line can lead to confusing results given the potential for other leak paths particularly on lots of other fittings. Special angled testers are also available for flanges fitted on bends.

A full range of standard flange weld testers are available up to 36" and compatible with common pipe schedules and flange configurations up to class 2500. Additional proven variations available include angled flange weld testers and increased expansion seal characteristics through patented composite Posi-seal™ technology. The design of such seals incorporates differing material hardness characteristics to withstand the continuous rigours of compression within the flange weld tester hub and expander but with the necessary reduction at the point of contact between the composite Posi-seal™ and the internal pipe wall which can be corroded or subject to hard deposition products.

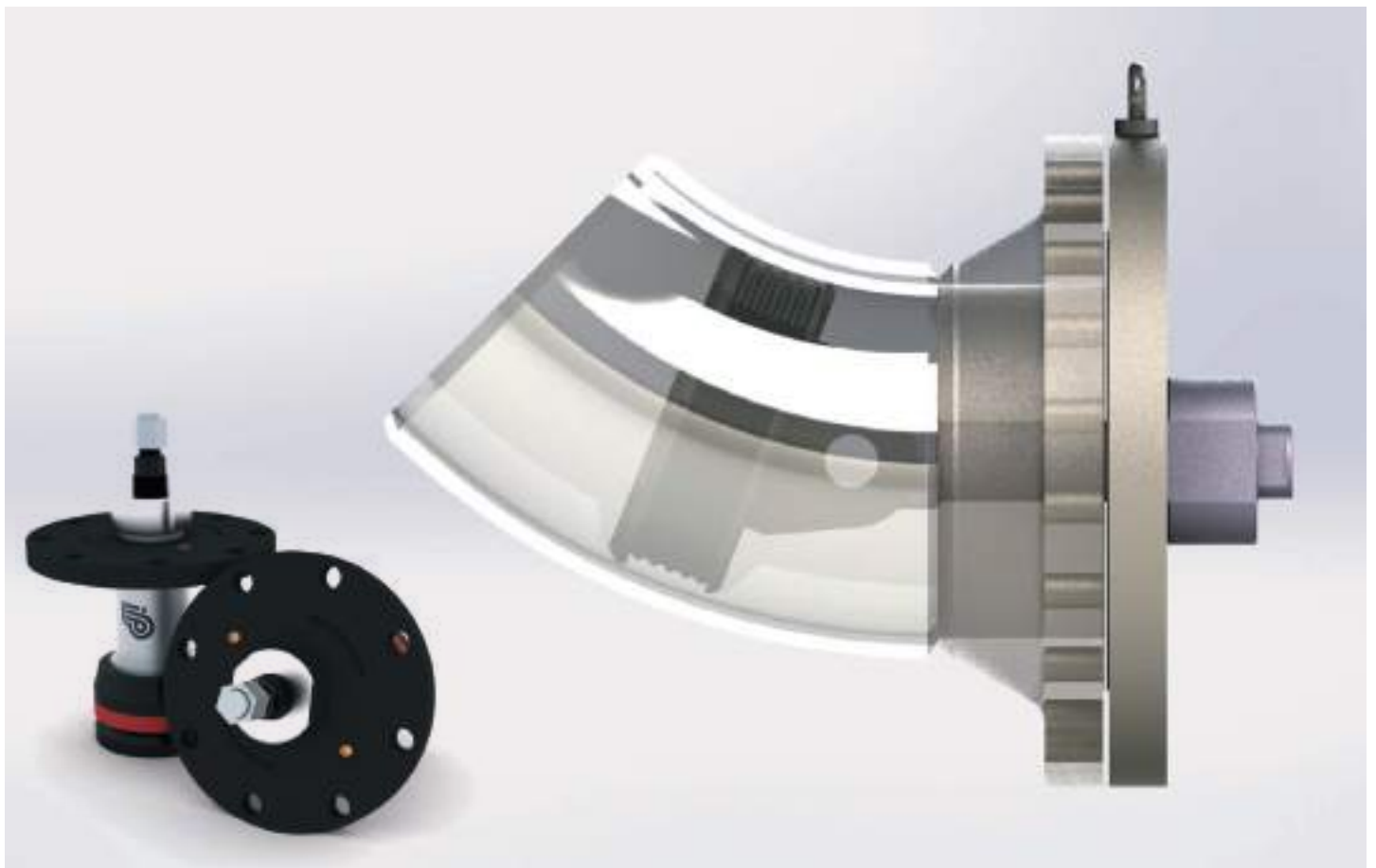



## INPIPE PRODUCTS™ Flange and internal weld tester operational benefits

- Products developed at client request, specified and approved by all UKOOA operators and contractors
- Reduced plant operation downtime and consequent revenue stream constraints
- Reduced modification labour time
- Accurate modification time scale as the overall scope of work is minimised
- No requirement to flood and subsequently dewater the whole pipe work system minimising time and consequent potential freeze damage
- No requirement for full system hydro-testing of 'mature' pipe work which can result in additional leakage problems
- Fully certified client training on site or factory training programmes
- All flange weld testers supplied complete with current hydro-test certificate and operational instructions
- On site **INPIPE PRODUCTS™** technicians available for training, technical support or tool installation and operation dependent upon client requirement
- Note: Site based Risk Assessments should always be conducted and remain the responsibility of the hiring client together with the responsibility to ensure that operators are trained in operation of the tools
- Simple installation and operation simply explained within the Operation Manual
- Easily installed and activated in a few minutes even in the larger sizes, designed with simple handling lugs for safe and easy handling
- Designed with sensible radial clearance to cope with potential insertion clearance operational problems such as excessive weld penetration, ovality or mineral deposits (please note: porous deposits will effect annulus pressurisation and may necessitate cleaning back to the steel substrate)
- Specialised tools can accommodate elbow, tee or extended actuation. Solid or inflatable Posi-seal™ options dependent upon rating and application
- Suitable for most test mediums of gas or liquid depending upon application
- High performance composite Posi-seal™ polyurethane seals ensure optimum expansion or relaxation. Additional ultra-low temperature composite Posiseal™ polyurethane grades are available upon technical specification
- Robust design and construction ensures many years of trouble free operation in the most difficult operational environments
- Years of continuous product development have ensured trouble-free chimney venting designs to ensure operation in any required pipe work orientation including vertical, horizontal or inclined



Vertical Orientation

Horizontal Orientation

Vertical Upside Down Orientation



Orientation and location of the weld tester must be taken into consideration to ensure that all air is effectively bled from the cavity area. Venting chimneys are available to cover any test orientation required.

All **INPIPE PRODUCTS™** testers are supplied with full operation instructions and training on site or at our manufacturing site in North Yorkshire. Our design engineers are also available for advice and technical support.

Internal, sometimes called in line weld testers, are also available from our extensive hire fleet in sizes to cover all schedules from 1/2" to 36".

Designed for butt weld testing they can also be used for valve testing and a number of other options, such as tees, in association with flange weld testers or high pressure plugs.

Our designers are available to discuss potential applications or requirements and advice from their extensive experience.

All weld testing equipment and plugs are available in mechanical and hydraulic options for tethered remote

operation depending upon size, location and actuation requirements.

All products are supplied complete with full factory acceptance pressure test certificates which can be third party witnessed (TPI) if required.

Internal weld testers can be used in a number of options and orientations for testing butt welds to line pipe. Mechanical and hydraulic options provide for local or remote actuation through extended hoses.

Internal weld testers can also be used to test the effective sealing of flange mounted ball valves. Dependent upon application, testers can be purpose manufactured to provide a specific length between the Posi-seals™.

Flange weld testing can be achieved by either using the bespoke flange weld tester or by using an internal weld tester as illustrated. The weld is again located between the two Posi-seals and the weld tested by pressure testing the cavity between the two energised seals.

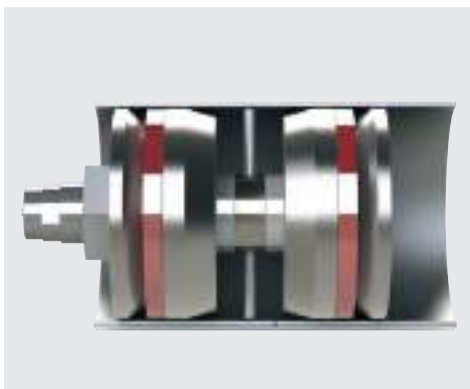

Pressure testing butt weld

Pressure testing valve

Pressure testing flange weld

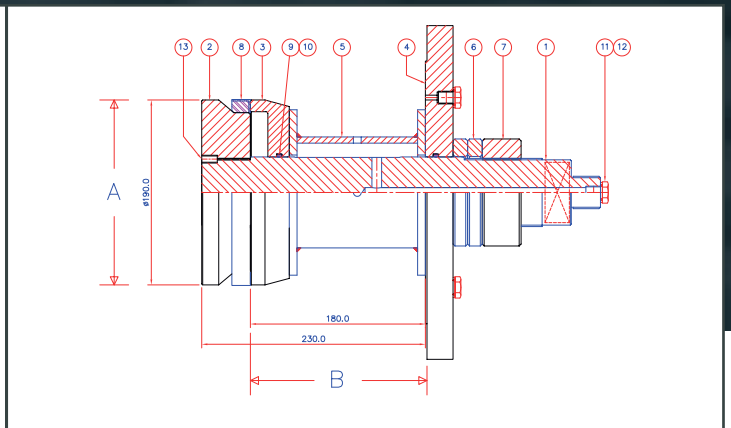
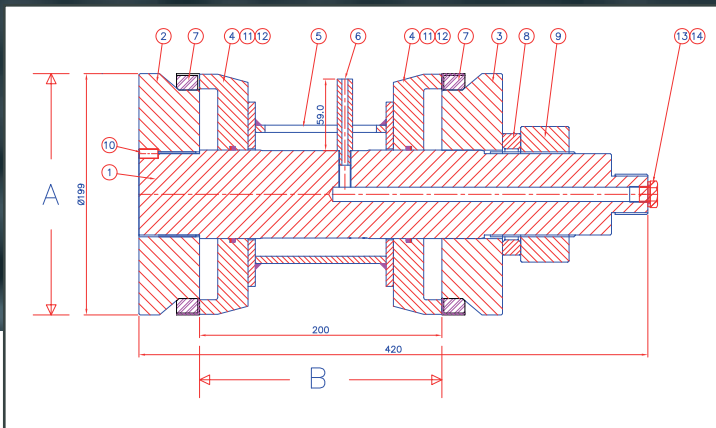

Internal weld tester parts list (mechanical)				Flange weld tester parts list (mechanical)			
Part	Description	Part	Description	Part	Description	Part	Description
1	Body	8	Spacer nut	1	Body	7	Nut
2/3	Front/rear hubs	9	Nut	2	Hub	8	Posi-seal™
4	Seal actuator	10	Vent Chimney	3	Seal Expander	9	'O' ring
5	Spacer	11	'O' ring	4	ANSI flange	10	Anti extrusion
6	Chimney	12	Anti extrusion	5	Spacer	11	Hex head plug
7	Posi-seal™	13	Hex head plug	6	Nut spacer	13	Grub screw
General dimensions	Dependant on schedule A	Seal distance B	Weight CL150	General dimensions	Dependant on schedule A	Seal distance B	Weight CL150
1"	33.4mm	70mm	1.2kg	1"	33.4mm	70mm	1.5kg
2"	60.3mm	80mm	3kg	2"	60.3mm	80mm	4kg
3"	88.9mm	115mm	6kg	3"	88.9mm	115mm	9.5kg
4"	114.3mm	145mm	8kg	4"	114.3mm	145mm	13kg
6"	168.3mm	175mm	20kg	6"	168.3mm	175mm	26kg
8"	219.1mm	200mm	40kg	8"	219.1mm	200mm	54kg
10"	273.1mm	200mm	65kg	10"	273.1mm	200mm	88kg
12"	323.9mm	200mm	95kg	12"	323.9mm	200mm	115kg

\*Larger sizes up to 36" available upon request and availability

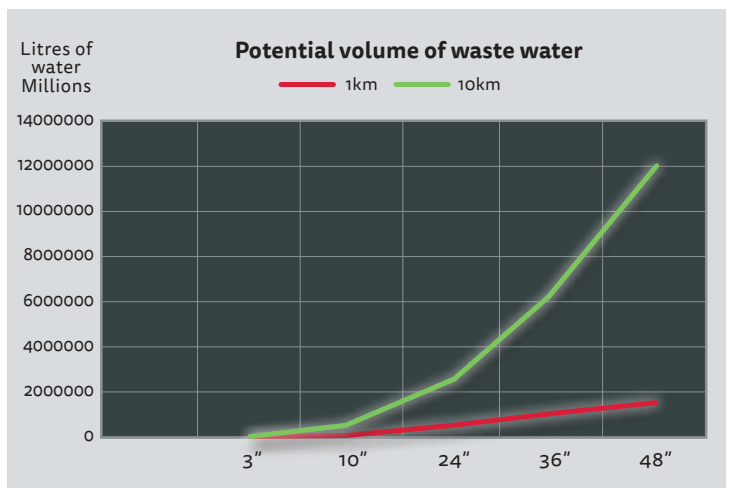
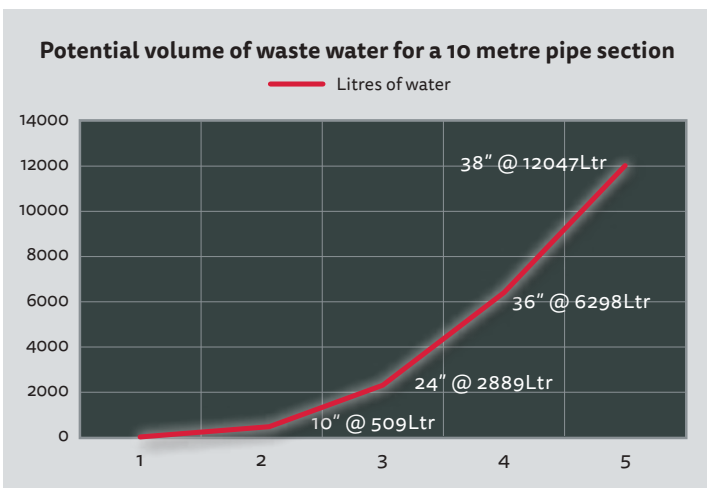

**INPIPE PRODUCTS™** flange weld testers significantly reduce polluted waste water production and helps to reduce the environmental impact of necessary pipe line repair and modification. For example, a 1km length of 24" pipe requires 228,000 litres of water to hydro-test compared to 140 litres for the **INPIPE PRODUCTS™** 24" flange weld tester.

## PIGGING PRODUCTS

Alongside our extensive product range, **iNPIPE PRODUCTS™** also has the capacity to offer custom engineering solutions.

### DELIVERY

**iNPIPE PRODUCTS™** is based on a 6 acre site housing all engineering, manufacturing and testing disciplines in 3 specific bays to ensure accurate project control and on time delivery all over the world.

The company has developed significant logistics skills and expertise to ensure that goods are shipped quickly, customs cleared and delivered to client's sites efficiently anywhere in the world in the shortest possible time.

Right first time ensures **iNPIPE PRODUCTS™** as the premier supplier of pigging products and services for over 30 years.

### SERVICE

**iNPIPE PRODUCTS™** provides pigging support services and tailored solutions for technically challenging pipeline conditions.

By precisely meeting our client's requirements and providing a turnkey solution, we have gained a significant reputation with major operators and contractors worldwide.

### TRAINING

**iNPIPE PRODUCTS™** provides comprehensive training courses of excellent quality.

The tutorial sessions provide individuals with an understanding of pigging / pipeline / isolation / testing and its applications.

Training tutorials can be conducted at our UK factory or at client's sites if required. Project/product specific certificates are issued upon successful completion of the course.

For further details, please contact **iNPIPE PRODUCTS™**

**iNPIPE PRODUCTS™** offers the latest in cutting edge technology, with design and manufacturing capabilities in-house.

**iNPIPE PRODUCTS™** facilities allow for the manufacture and production of both standard and customised products, with turning and forming machinery for the production of high quality machined parts.

**iNPIPE PRODUCTS™** places emphasis on providing client-led solutions and offering a full advisory service.

**iNPIPE PRODUCTS™** provides an unrivalled product range that includes Metal Bodied Pigs/Scrapers, Foam Pigs, Spheres, Weld Testers, Pig Signallers as well as Launching and Receiving hardware. We are world leaders in the design and manufacture of pigging, pipeline pigging and pigging components.



**iNPIPE  
PRODUCTS**

Gatherley Road, Brompton on Swale, North Yorkshire, England, DL10 7JH

Tel: +44 (0)1748 813270

Fax: +44 (0)1748 813454

sales@inpipeproducts.co.uk

www.inpipeproducts.com

